

# RESURFACING CONTRACT: DB00201

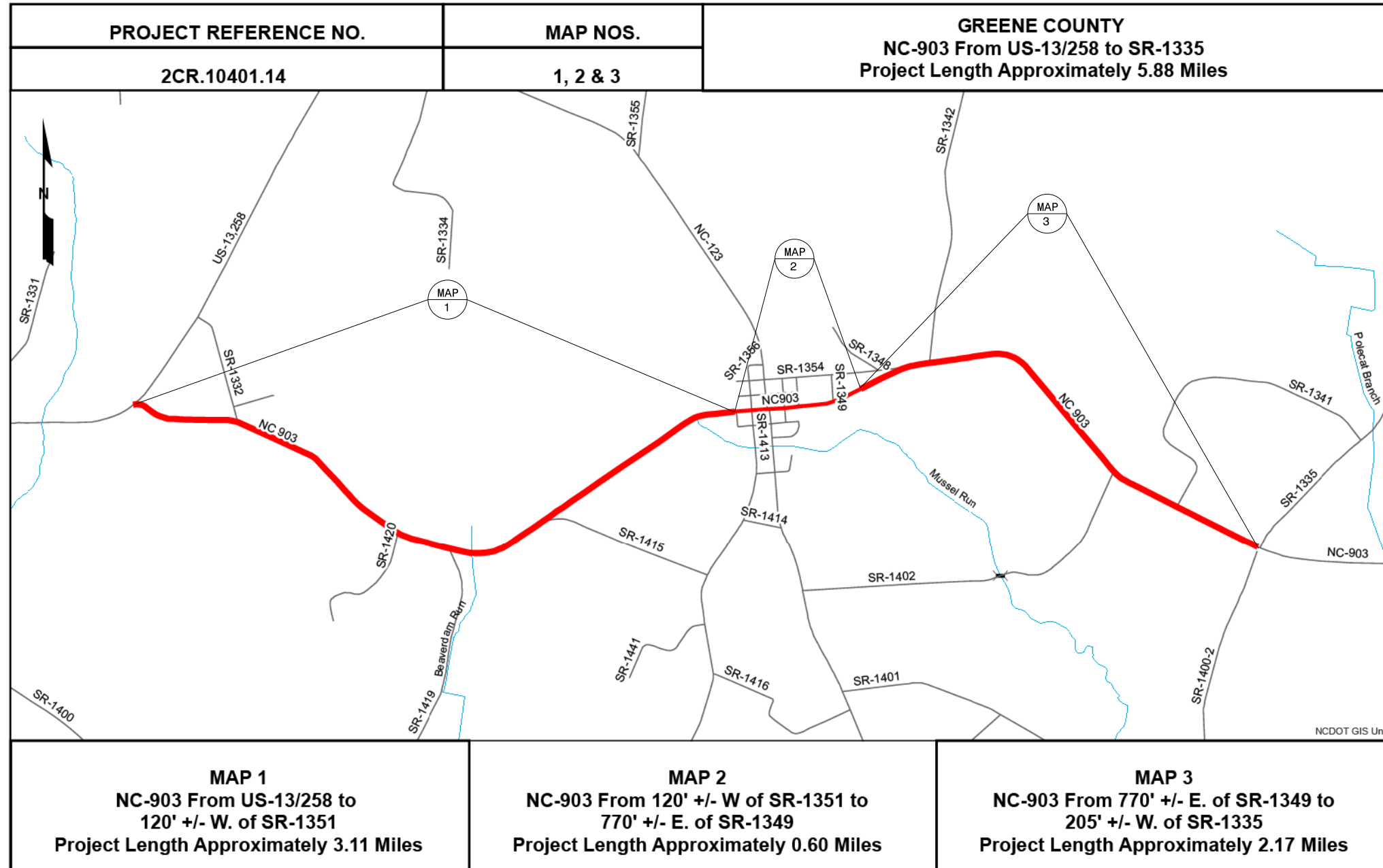

### TYPICAL SECTION NO. 1

MAP 1: NC903 FROM US-13/258 TO 120' +/- W. OF SR-1351

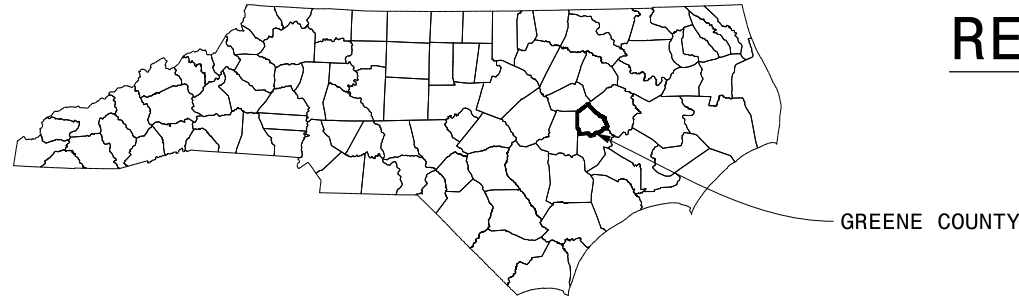
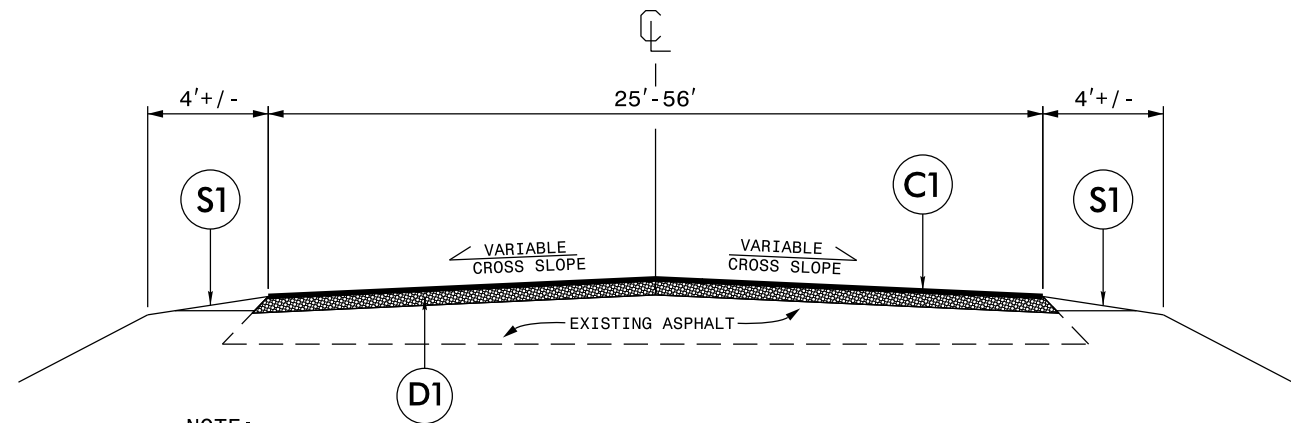

- NOTE:**
1. PLACE ASPHALT SURFACE COURSE AT FULL WIDTH OF EXISTING ASPHALT PAVEMENT.
  2. PLACE ASPHALT INTERMEDIATE COURSE AT FULL WIDTH OF EXISTING ASPHALT PAVEMENT.
  3. INCLUDES INCIDENTAL MILLING AT THE ENDS OF MAIN LINE SECTIONS AND BRIDGE APPROACH TIE-INS, OR AS DIRECTED BY THE ENGINEER. SEE DETAIL 1 & 2

### TYPICAL SECTION NO. 2

MAP 2: NC903 FROM 120' +/- W. OF SR-1351 TO 770' +/- E. OF SR-1349

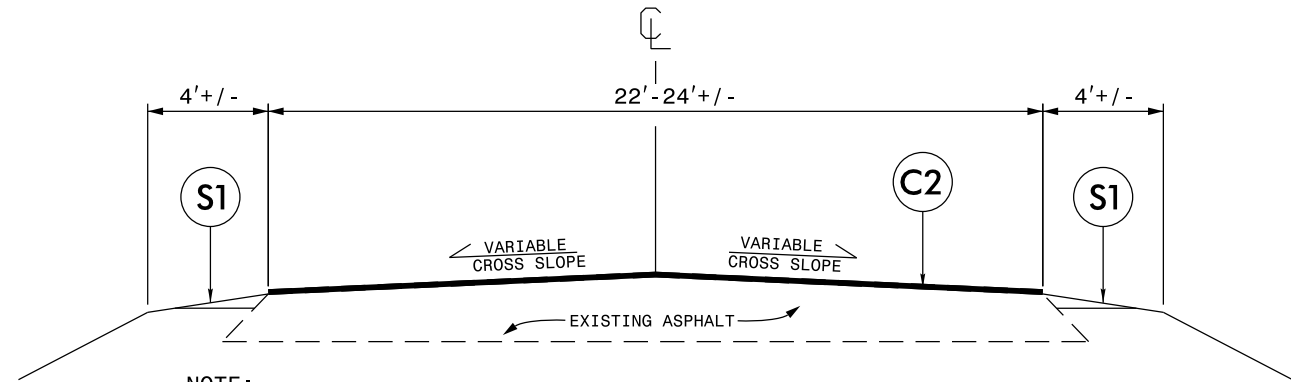

- NOTE:**
1. PLACE ASPHALT SURFACE COURSE AT FULL WIDTH OF EXISTING ASPHALT PAVEMENT, AS DIRECTED BY THE ENGINEER.
  2. INCLUDES INCIDENTAL MILLING AT THE ENDS OF MAIN LINE SECTIONS AND BRIDGE APPROACH TIE-INS, OR AS DIRECTED BY THE ENGINEER. SEE DETAIL 1 & 2

### TYPICAL SECTION NO. 3

MAP 3: NC903 FROM 770' +/- E. OF SR-1349 TO 205' +/- W. OF SR-1335

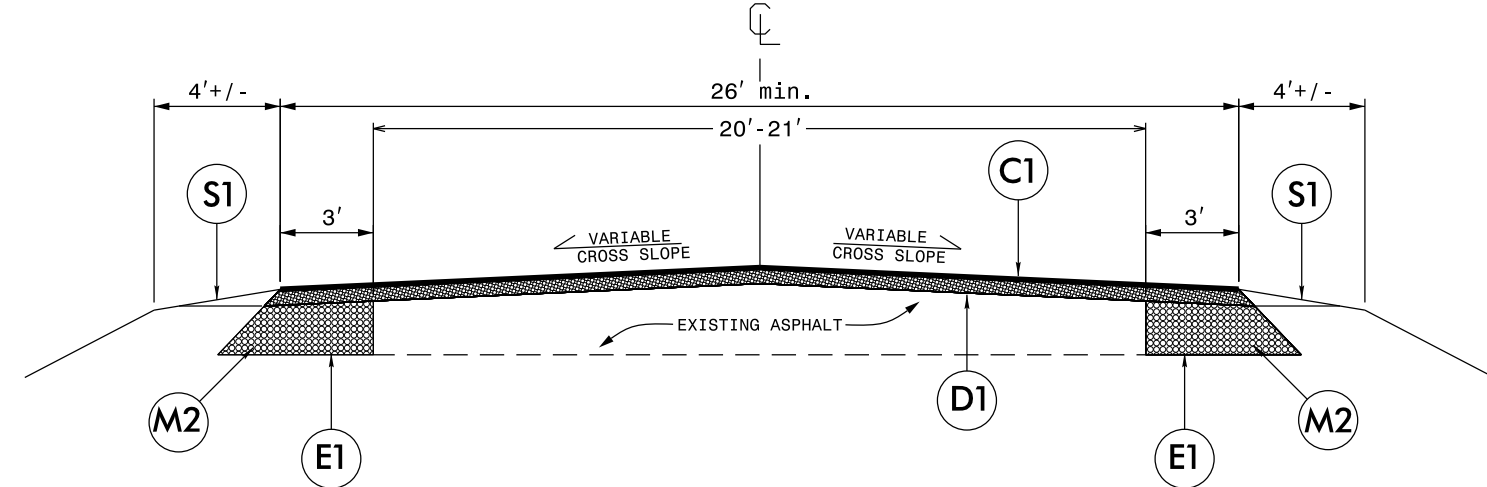

- NOTE:**
1. PLACE 3' SYMMETRICAL WIDENING. MAKE FLUSH WITH THE EXISTING ASPHALT.
  2. TRENCHING SHALL BE PERFORMED USING A MILLING MACHINE OR SIMILAR DEVICE.
  3. PLACE ASPHALT INTERMEDIATE COURSE AT FULL WIDTH, INCLUDING NEW WIDENING.
  4. PLACE ASPHALT SURFACE COURSE AT FULL WIDTH, INCLUDING NEW WIDENING.

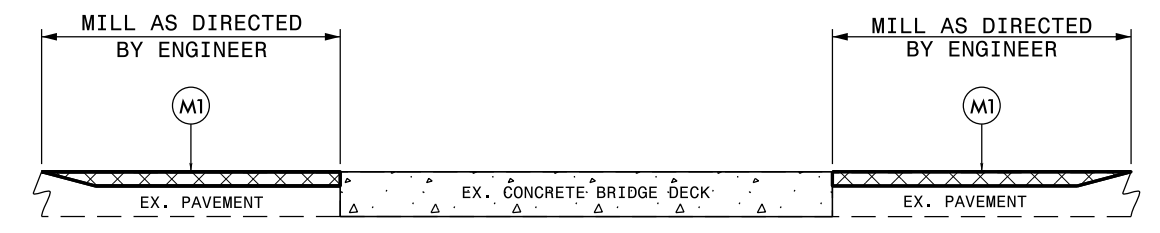

**DETAIL 2**  
BRIDGE MILLING

- NOTE:**
1. MILLING SHALL BE PERFORMED AT BRIDGE DECKS AND BRIDGE APPROACHES AS DIRECTED BY THE ENGINEER, IN ACCORDANCE WITH THIS DETAIL.

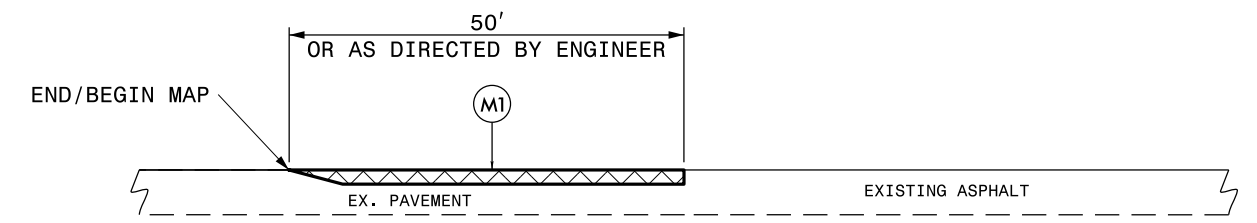

**DETAIL 1**  
MAIN LINE MILLING

- NOTE:**
1. INCLUDES INCIDENTAL MILLING AT THE ENDS OF MAIN LINE SECTIONS, OR AS DIRECTED BY THE ENGINEER.
  2. PAVE TO THE END OF THE MILLED SURFACE TO CREATE A SMOOTH TRANSITION.

PAVEMENT SCHEDULE	
C1	PROP. APPROX. 1½" OF ASPHALT CONCRETE SURFACE COURSE, TYPE S9.5B, AT AN AVERAGE RATE OF 168 LBS. PER SQ. YD.
C2	PROP. APPROX. 1¾" OF ASPHALT CONCRETE SURFACE COURSE, TYPE S9.5B, AT AN AVERAGE RATE OF 196 LBS. PER SQ. YD.
D1	PROP. APPROX. 2½" OF ASPHALT CONCRETE INTERMEDIATE COURSE, TYPE I19.0B, AT AN AVERAGE RATE OF 285 LBS. PER SQ. YD.
E1	PROP. APPROX. 5½" OF ASPHALT CONCRETE BASE COURSE, TYPE B-25.0B, AT AN AVERAGE RATE OF 627 LBS. PER SQ. YD.
M1	MILLING DEPTH 0"-2" AT ALL BRIDGE APPROACHES, FOR THE ENTIRE WIDTH OF THE ROADWAY, OR AS DIRECTED BY THE ENGINEER.
M2	MILLING EXISTING SOIL SHOULDER, TO A DEPTH OF 5½", WITH A WIDTH OF 3' WHERE INDICATED BY TYPICAL, FOR SYMMETRICAL WIDENING.
S1	SHOULDER RECONSTRUCTION AS DIRECTED BY THE ENGINEER.

**DRAWINGS NOT TO SCALE**

NOTE: PAVEMENT EDGE SLOPES ARE 1:1 UNLESS SHOWN OTHERWISE.

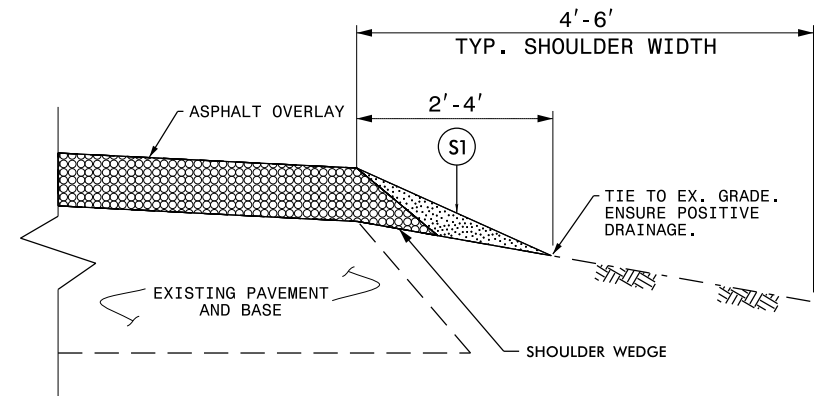

**SHOULDER RECONSTRUCTION DETAIL**

**NOTE:**

1. SHOULDERS SHALL BE RECONSTRUCTED AS SHOWN IN STD. DWG. NO. 560.01 & 560.02, WITH A MINIMUM SLOPE OF 1" PER FOOT TO ENSURE POSITIVE DRAINAGE AWAY FROM THE ROADWAY.
2. A VEGETATIVE BUFFER SHALL BE MAINTAINED BETWEEN THE DISTURBED AREA ALONG THE EDGE OF PAVEMENT AND THE DITCH SHOULDER POINT TO MINIMIZE EROSION. PULLING DITCHES OR CUTTING SHOULDERS TO GENERATE BORROW MATERIAL WILL NOT BE ALLOWED.
3. REQUIRED BORROW MATERIAL MAY BE OBTAINED FROM NCDOT APPROVED BORROW PITS OR FROM NCDOT STOCKPILES. ANY EXCESS MATERIAL SHALL BE DISPOSED OF BY THE CONTRACTOR IN AN APPROVED DISPOSAL SITE.

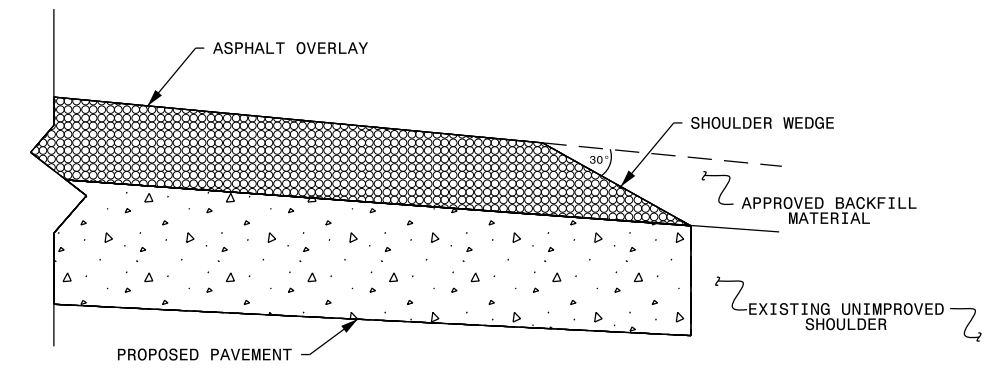

**SHOULDER WEDGE DETAIL**  
(Resurfacing Projects w/ Widening or with Existing Paved Shoulder having no dropoffs)

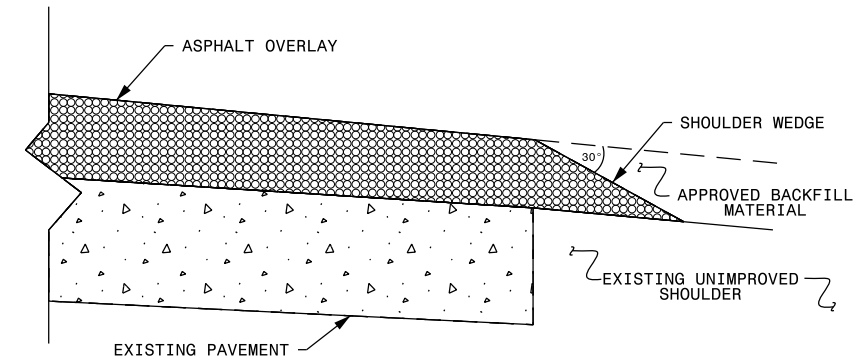

**SHOULDER WEDGE DETAIL**  
(Resurfacing Projects w/ no Widening)

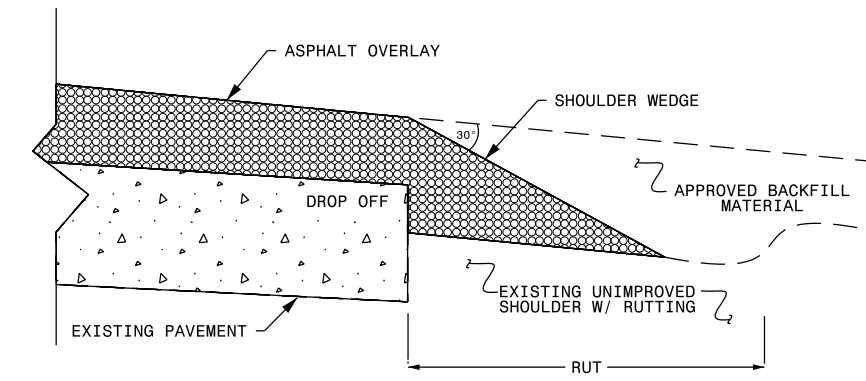

**SHOULDER WEDGE DETAIL**  
(Resurfacing Adjacent to Rutted Shoulder)

**DETAIL SHOULDER WEDGE DETAILS**

- NOTES:**
1. DETAIL DOES NOT APPLY TO OGAFB AND ULTRA-THIN BONDED WEARING COURSE.
  2. BACKFILL SHOULDER WITH APPROVED MATERIAL.
  3. THE SHOULDER WEDGE DEVICE MAY BE DISENGAGED AT PAVED DRIVEWAYS AND SIDE STREETS.

PAVEMENT SCHEDULE	
C1	PROP. APPROX. 1½" ASPHALT CONCRETE SURFACE COURSE, TYPE S9.5B, AT AN AVERAGE RATE OF 168 LBS. PER SQ. YD.
C2	PROP. APPROX. 1¾" ASPHALT CONCRETE SURFACE COURSE, TYPE S9.5B, AT AN AVERAGE RATE OF 196 LBS. PER SQ. YD.
D1	PROP. APPROX. 2½" ASPHALT CONCRETE INTERMEDIATE COURSE, TYPE I19.0B, AT AN AVERAGE RATE OF 285 LBS. PER SQ. YD.
E1	PROP. APPROX. 5½" ASPHALT CONCRETE BASE COURSE, TYPE B-25.0B, AT AN AVERAGE RATE OF 627 LBS. PER SQ. YD.
M1	PROP. APPROX. 0"-2" AT ALL BRIDGE APPROACHES, FOR THE ENTIRE WIDTH OF THE ROADWAY, OR AS DIRECTED BY THE ENGINEER.
M2	MILLING EXISTING SOIL SHOULDER, TO A DEPTH OF 5½", WITH A WIDTH OF 3' WHERE INDICATED BY TYPICAL, FOR SYMMETRICAL WIDENING.
S1	SHOULDER RECONSTRUCTION AS DIRECTED BY THE ENGINEER.

**DRAWINGS NOT TO SCALE**

NOTE: PAVEMENT EDGE SLOPES ARE 1:1 UNLESS SHOWN OTHERWISE.

## SUMMARY OF QUANTITIES

PROJECT NO.
2CR.10401.14

PROJECT NO	COUNTY	MAP NO	ROUTE	DESCRIPTION	TYP NO	LANES	LANE TYPE	FINAL SURFACE TESTING REQUIRED	WARM MIX ASPHALT REQUIRED	LENGTH MI	WIDTH FT	INCIDENTAL STONE BASE TONS	SHOULDER RECONSTRUCTION SMI	0" TO 2" MILLING SY	INCIDENTAL MILLING SY	BASE COURSE, B25.0B TONS	INTERMEDIATE COURSE, I19.0B TONS	SURFACE COURSE, S9.5B TONS	ASPHALT BINDER FOR PLANT MIX TONS	ADJ. OF MANHOLES EA	ADJ. OF METER OR VALVE BOX EA	TEMPORARY SILT FENCE LF	WATTLE LF	SEEDING & MULCHING AC
2CR.10401.14	Greene	1	NC 903	FROM US13/258 TO 120'+/- W OF SR-1351		2	2WU	NO	NO	3.11	25	250	6.50		400		6,800	4,000	566			350	220	3.50
<b>TOTAL FOR MAP NO. 1</b>										<b>3.11</b>		<b>250</b>	<b>6.50</b>		<b>400</b>		<b>6,800</b>	<b>4,000</b>	<b>566</b>			<b>350</b>	<b>220</b>	<b>3.50</b>
2CR.10401.14	Greene	2	NC 903	FROM 120'+/- W OF SR 1351 TO 770'+/- E. OF SR-1349		2	2WU	NO	NO	0.6	21	45	1.20					850	51	7	4	100	50	1.00
<b>TOTAL FOR MAP NO. 2</b>										<b>0.6</b>		<b>45</b>	<b>1.20</b>					<b>850</b>	<b>51</b>	<b>7</b>	<b>4</b>	<b>100</b>	<b>50</b>	<b>1.00</b>
2CR.10401.14	Greene	3	NC 903	FROM 770'+/- E. OF SR 1349 TO 205'+/- W OF SR-1335		2	2WU	NO	NO	2.17	26	250	4.50	800	400	2,754	5,120	2,981	546			300	200	3.00
<b>TOTAL FOR MAP NO. 3</b>										<b>2.17</b>		<b>250</b>	<b>4.50</b>	<b>800</b>	<b>400</b>	<b>2,754</b>	<b>5,120</b>	<b>2,981</b>	<b>546</b>			<b>300</b>	<b>200</b>	<b>3.00</b>
<b>TOTAL FOR PROJ NO. 2CR.10401.14</b>										<b>5.88</b>		<b>545</b>	<b>12.20</b>	<b>800</b>	<b>800</b>	<b>2,754</b>	<b>11,920</b>	<b>7,831</b>	<b>1,163</b>	<b>7</b>	<b>4</b>	<b>750</b>	<b>470</b>	<b>7.50</b>
<b>GRAND TOTAL</b>										<b>5.88</b>		<b>545</b>	<b>12.20</b>	<b>800</b>	<b>800</b>	<b>2,754</b>	<b>11,920</b>	<b>7,831</b>	<b>1,163</b>	<b>7</b>	<b>4</b>	<b>750</b>	<b>470</b>	<b>7.50</b>

# T H E R M O P L A S T I C   A N D   P A I N T   Q U A N T I T I E S

PROJECT NO. 2CR.10401.14
-----------------------------

PROJECT NO	COUNTY	MAP NO	ROUTE	DESCRIPTION	TYP NO	LANES	LANE TYPE	LENGTH	WIDTH	4413000000-E	4457000000-N	4810000000-E		4835000000-E	4845000000-N
										WORK ZONE ADVANCE/ GENERAL WARNING SIGNING SF	TEMPORARY TRAFFIC CONTROL LS	4" WHITE PAINT LF	4" YELLOW PAINT LF	24" WHITE PAINT LF	PAINT LT ARROW EA
2CR.10401.14	Greene	1	NC 903	FROM US13/258 TO 120'+/- W OF SR-1351	1	2	2WU	3.11	25	1,000	1	67,000	41,100	36	4
<b>TOTAL FOR MAP NO. 1</b>					<b>1</b>			<b>3.11</b>		<b>1,000</b>	<b>1</b>	<b>67,000</b>	<b>41,100</b>	<b>36</b>	<b>4</b>
2CR.10401.14	Greene	2	NC 903	FROM 120'+/- W OF SR-1351 TO 770'+/- E. OF SR-1349	1	2	2WU	0.6	21	800	1	6,456	3,960		
<b>TOTAL FOR MAP NO. 2</b>					<b>1</b>			<b>0.6</b>		<b>800</b>	<b>1</b>	<b>6,456</b>	<b>3,960</b>		
2CR.10401.14	Greene	3	NC 903	FROM 770'+/- E. OF SR-1349 TO 205'+/- W OF SR-1335	1	2	2WU	2.17	26	566	1	47,000	28,700		
<b>TOTAL FOR MAP NO. 3</b>					<b>1</b>			<b>2.17</b>		<b>566</b>	<b>1</b>	<b>47,000</b>	<b>28,700</b>		
<b>TOTAL FOR PROJ NO. 2CR.10401.14</b>								<b>5.88</b>		<b>2,366</b>	<b>3</b>	<b>120,456</b>	<b>73,760</b>	<b>36</b>	<b>4</b>
										<b>194,216</b>					
<b>GRAND TOTAL</b>								<b>5.88</b>		<b>2,366</b>	<b>3</b>	<b>120,456</b>	<b>73,760</b>	<b>36</b>	<b>4</b>
										<b>194,216</b>					